

I-DUATLÓN SOLIDARIO UTEBO

Modalidad:

CROSS

27 de febrero de 2011

Plaza Ayuntamiento

11:00 horas



Más información en:
ceutebo.blogspot.com
www.clubciclistautebo.es
clubtriathlonutebo.blogspot.com

A beneficio de:



Organizado por:



Colabora:

Patrocinado por:



1º SEGMENTO

5,9 Km – Carrera a Pie

(1 vuelta pueblo + 2 vueltas parque)

2º SEGMENTO

19,25 Km – Ciclismo BTT

(1 vuelta dehesa del Ebro)

3º SEGMENTO

2,67 Km – Carrera a Pie

(1 vuelta parque)



I-DUATLÓN SOLIDARIO

1ª Carrera: 1ª Vuelta

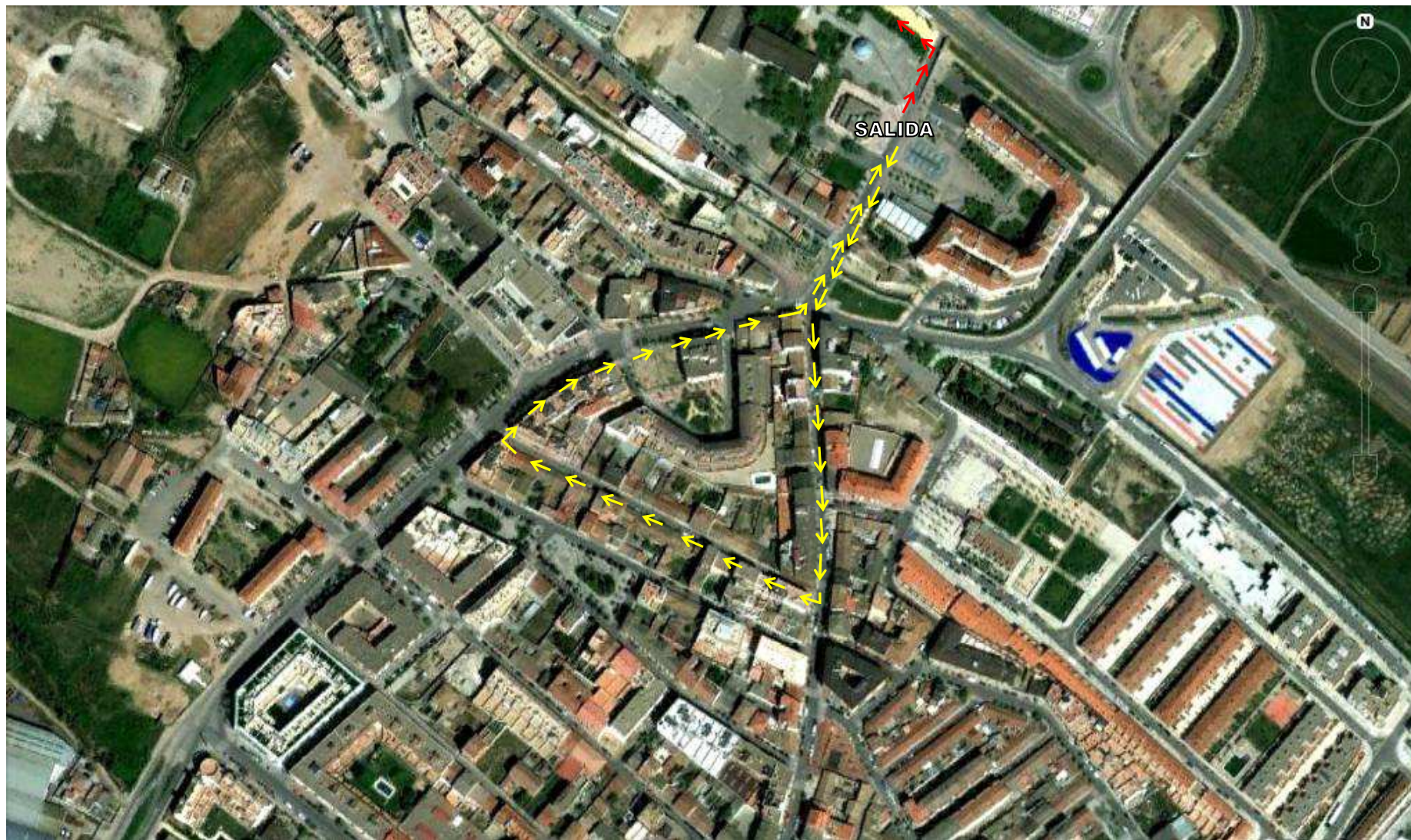



I-DUATLÓN SOLIDARIO



1ª Carrera: Inicio 2ª Vuelta

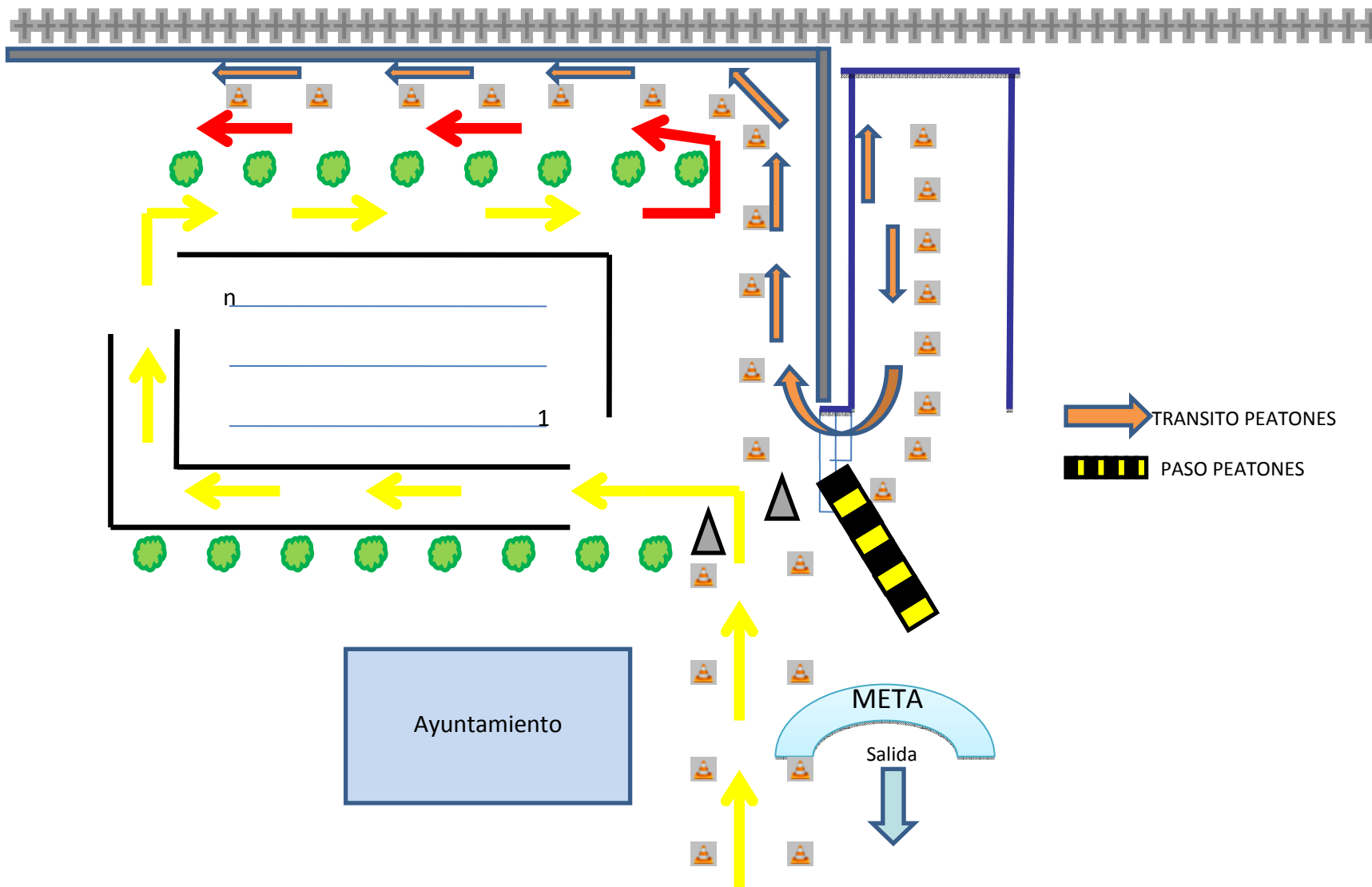



I-DUATLÓN SOLIDARIO

1ª Carrera: 2ª Vuelta





I-DUATLÓN SOLIDARIO



1ª Carrera: Inicio 3ª Vuelta

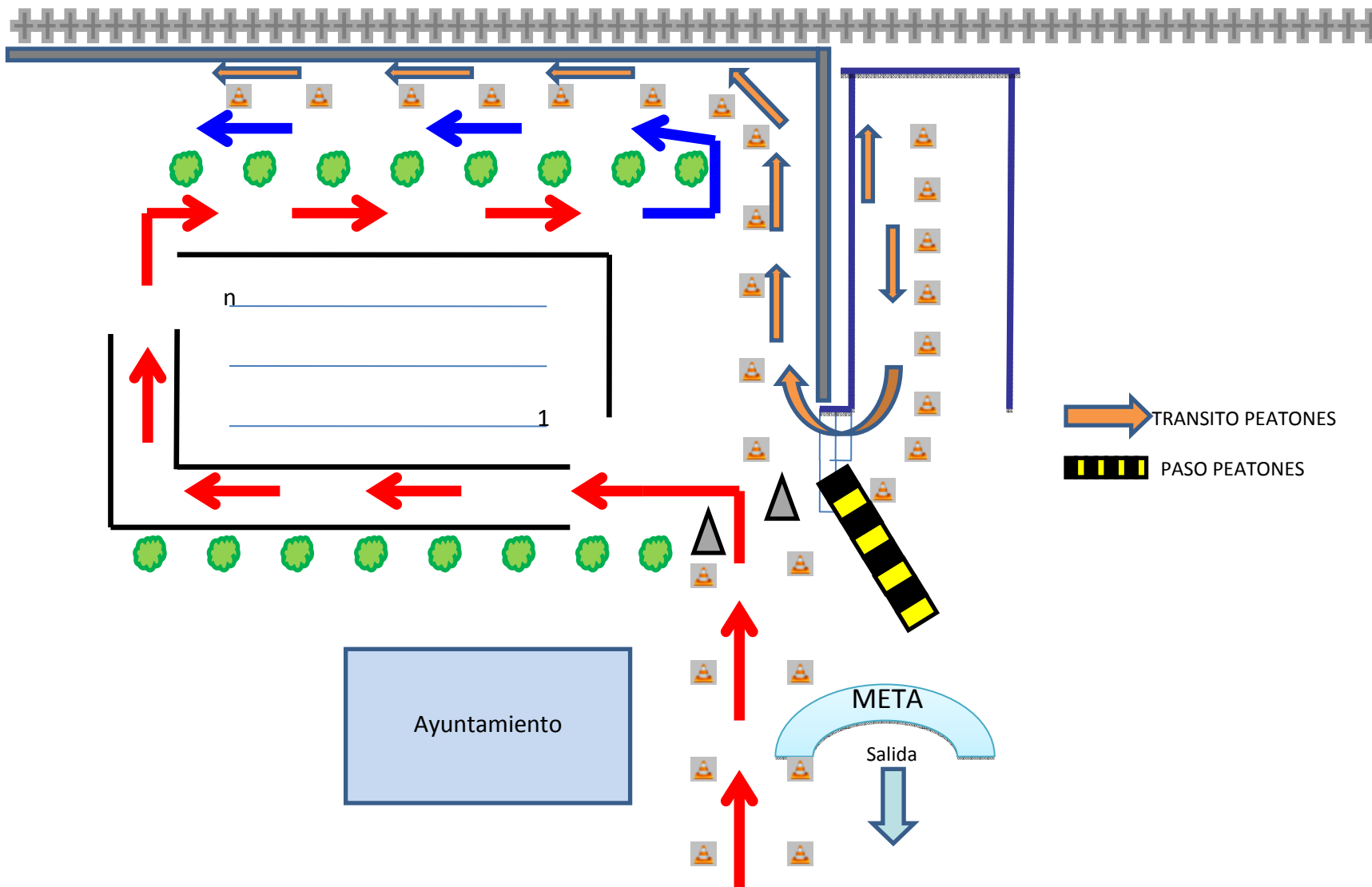



I-DUATLÓN SOLIDARIO

1ª Carrera: 3ª Vuelta





I-DUATLÓN SOLIDARIO

Entrada AT Carrera

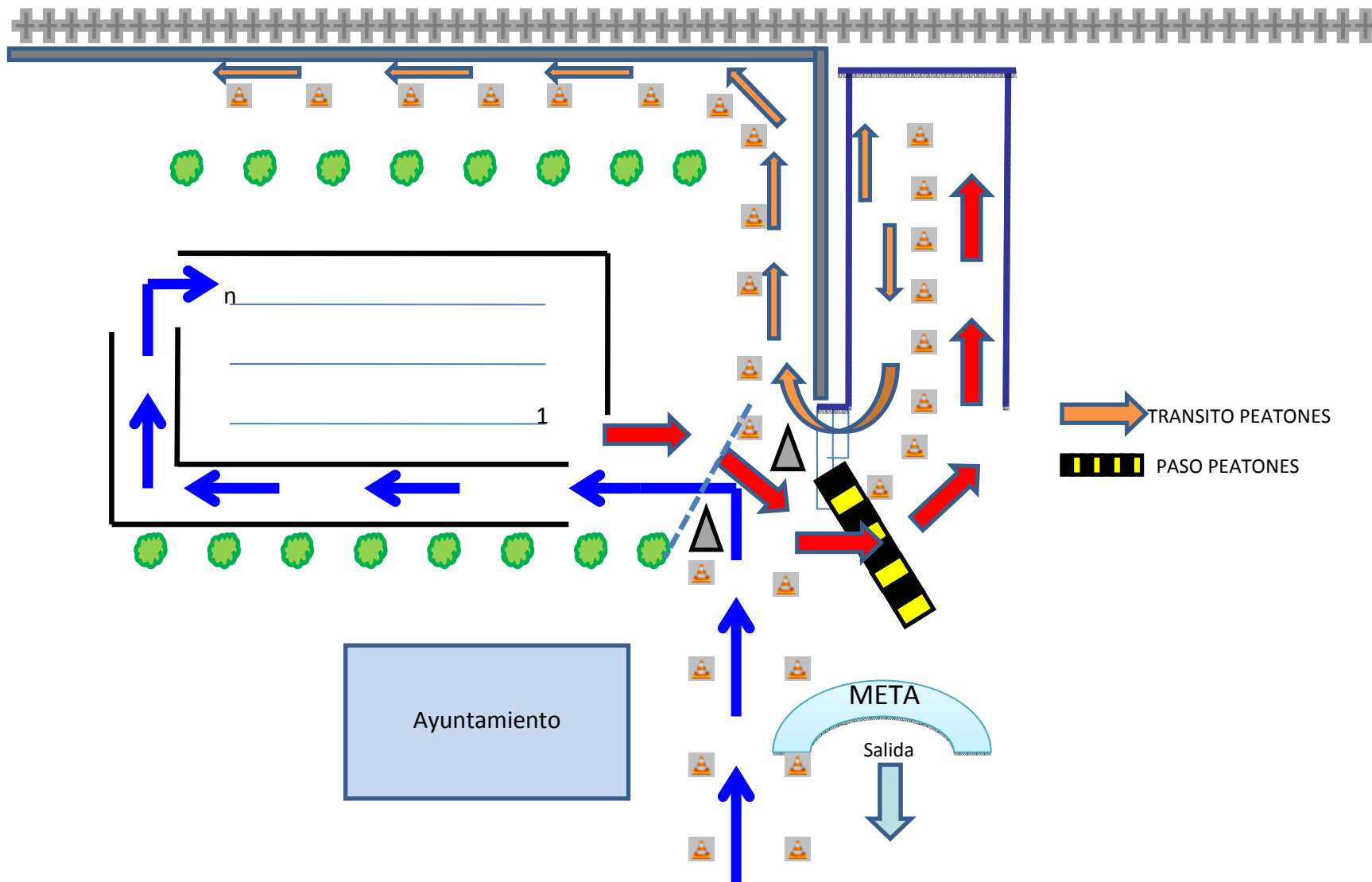



I-DUATLÓN SOLIDARIO

Desplazamientos Área Transición

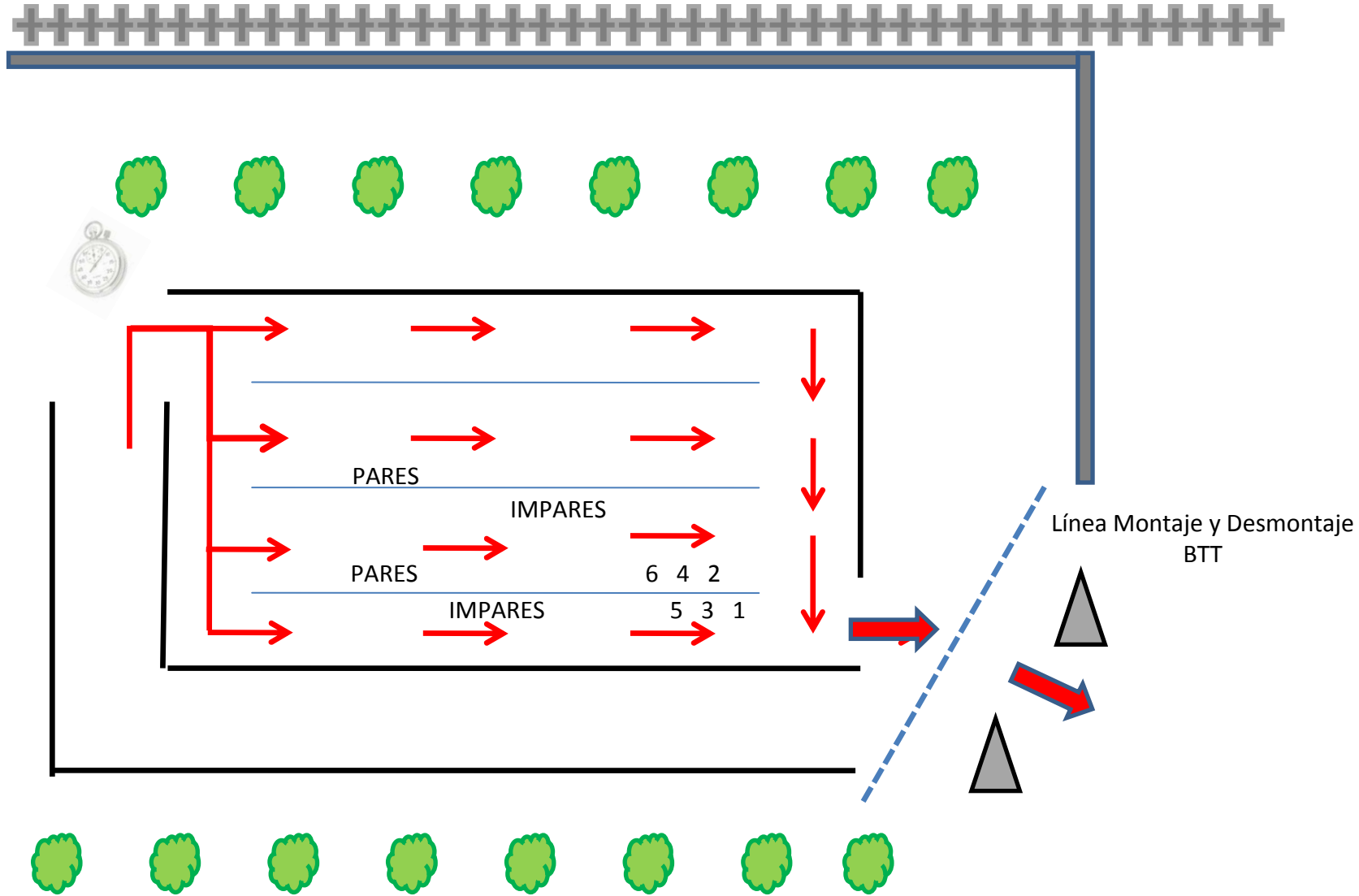



I-DUATLÓN SOLIDARIO

Ciclismo BTT





I-DUATLÓN SOLIDARIO

Entrada AT Ciclismo

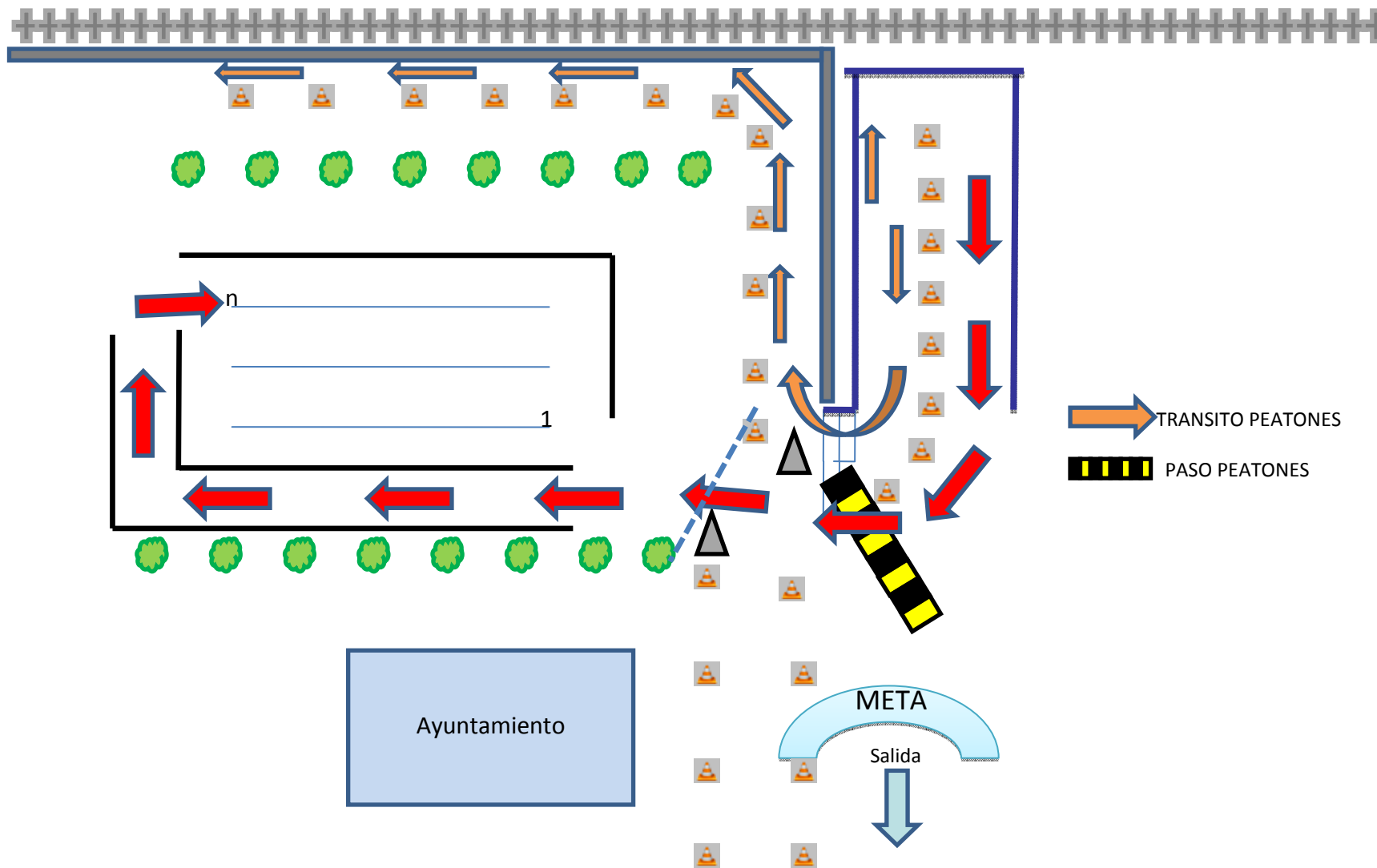



I-DUATLÓN SOLIDARIO

2ª Carrera





I-DUATLÓN SOLIDARIO



Entrada Meta

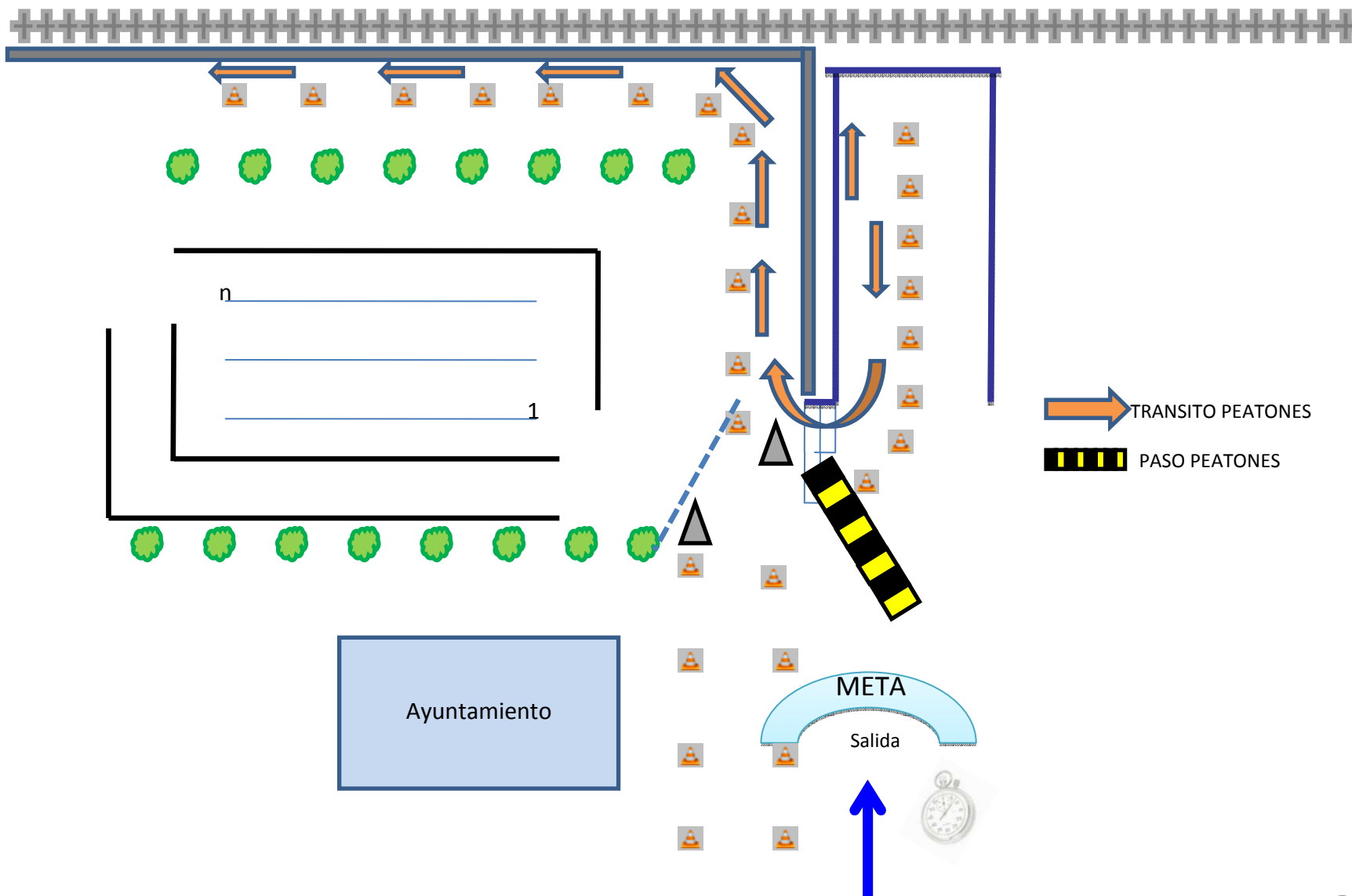

TRANSITO PEATONES
PASO PEATONES



I-DUATLÓN SOLIDARIO

Aparcamientos + Duchas

